

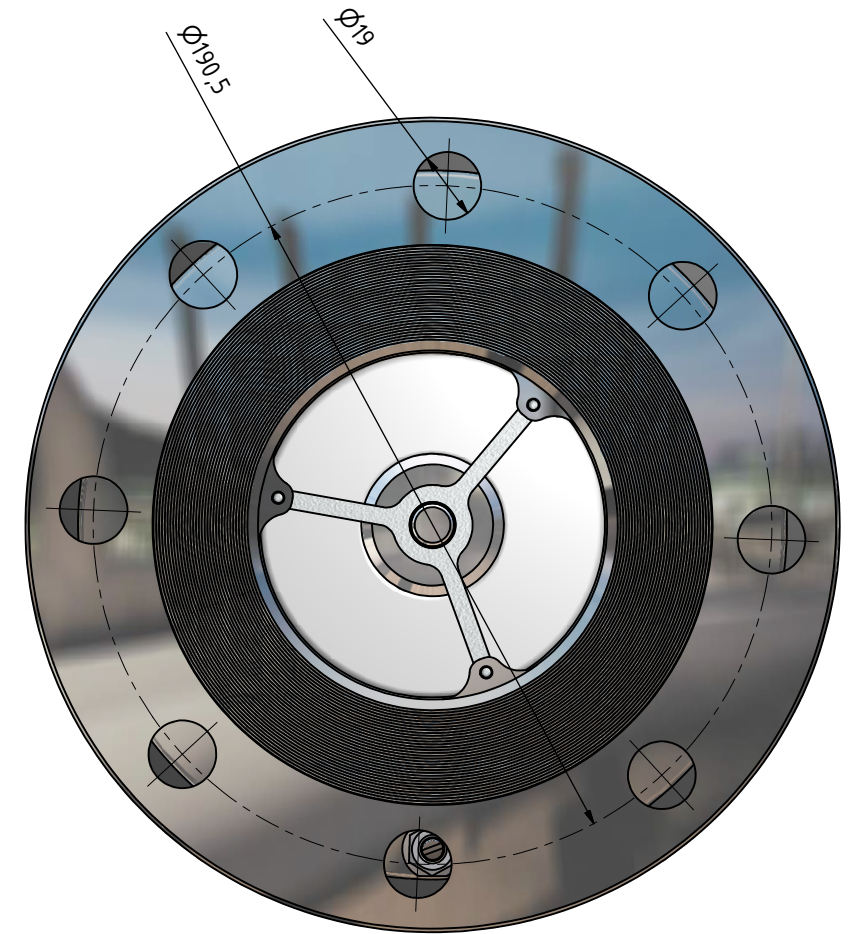

Notice: This drawing contains proprietary information and shall not be used or reproduced or its contents disclosed in whole or in part, without the prior written consent of the Mann Teknik AB

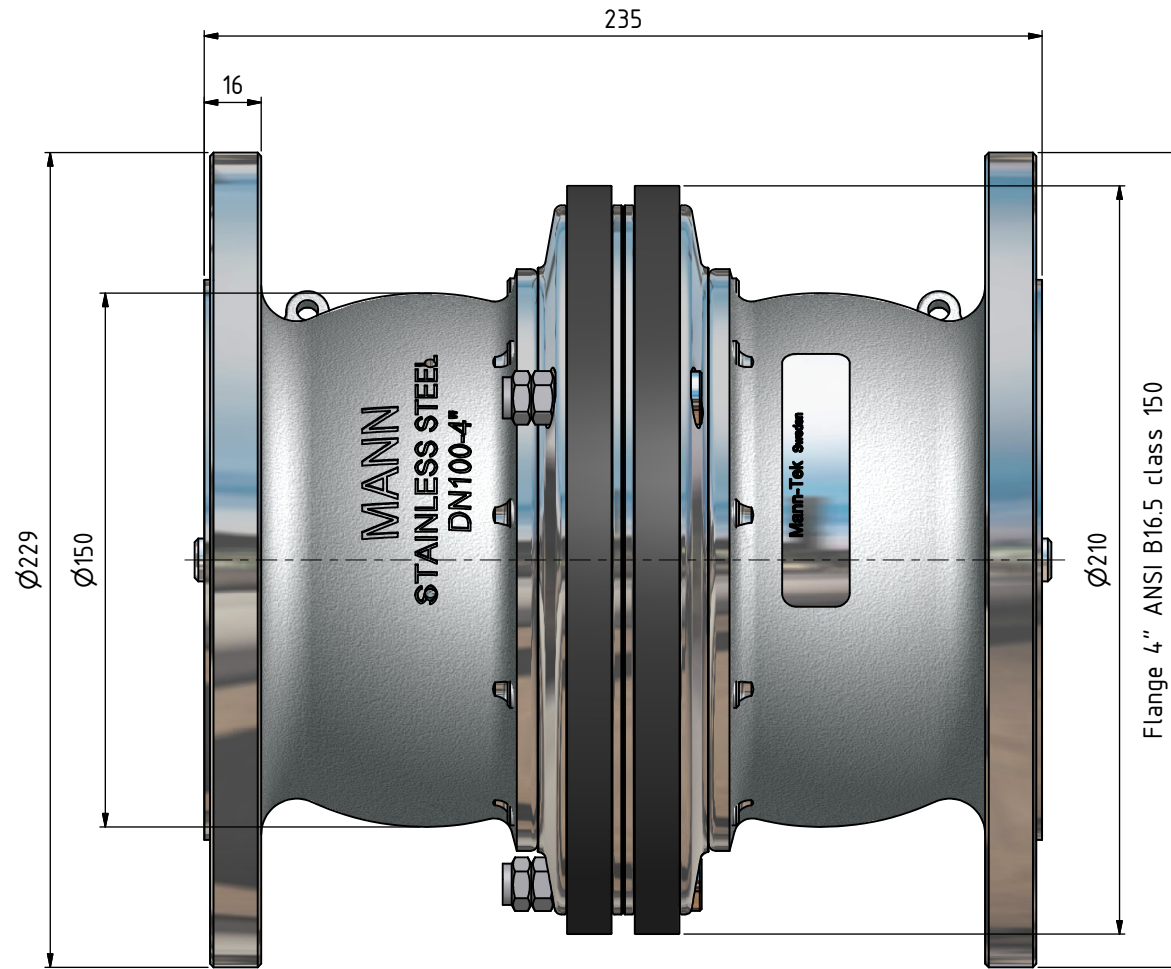

Weight: 19.6 kg

Dimensions are in metric.

| Detail No: | Material | Ämne/Blank | Ytbeh./Treatment | Vikt/Weight |
|---|--------------------------------|---------------|--|---------------------|
|  | Designed/drawn by P. Nyberg | Scale: 1:2 | Dimension with no tolerances acc to Machined SS-ISO 2768-1 medium Weld Forge SS-ISO 2768-1 coarse Surface roughness ISO 1302 Form & position tol SS ISO 1101 | |
| | Checked G. Kopplin | | | |
| | Approved T. Mann | | | |
| | | | | |
| Industrial Break Away 4" Flange 4" class 150 | | | Data nr./Comp No. N563D4401 | Blad/Sheet 1 / 1 |
| | | | Drawing No. N563D4401-1 | Rev. |

| NO. | Revision comprises | Date | Sign. | Appr by |
|-----|--------------------|------|-------|---------|
| | | | | |